

SFX-8445/8460



STEREO POWERED MIXER



FEATURES

- 8 Mono and 4 Stereo input channels.
- Stereo or Main/Monitor operation modes.
- 3 band equalizer on each mono input channel.
- +48V phantom power.
- Dual 9 band graphic equalizers.
- 24 bit digital effects.
- Break(Intermission) switch for muting all but the stereo inputs.

SPECIFICATIONS

■ ELECTRICAL

* 0dB=0.775Vrms

· Rated Output

	SFX-8445	SFX-8460
2Ω(Stereo)	450W+450W	600W+600W
4Ω(Stereo)	300W+300W	450W+450W
8Ω(Bridged)	200W+200W	300W+300W

- Input Sensitivity/Impedance
 - Mic In(Mono Channel).....-50dB/4kΩ, BAL
 - Line In(Mono Channel).....-30dB/10kΩ, BAL
 - ST Line In(Stereo Channel)-20dB/5kΩ, UNBAL
 - Tape In.....-10dBV/10kΩ, UNBAL
 - Aux In.....+4dB/10kΩ, UNBAL
- Frequency Response(+1/-3dB)20Hz-20kHz
- T.H.D(20Hz-20kHz)
 - Mixer Section0.1%
 - Amp Section.....0.5%
- Tone Control
 - High/Low(12kHz/80Hz).....±15dB
 - Mid(2.5kHz)±12dB
- Graphic Equalizer(±12dB)9 Band(Max)
 - 63, 125, 250, 500, 1k, 2k, 4k, 8k, 16kHz
- EIN-128dB
- BUSS NOISE-78dB
- CROSSTALK.....-70dB
- Internal 24bit Digital Effect

■ GENERAL

- Power SourceAC 100V/120V/230V/240V, 50/60Hz
- Power ConsumptionSFX-8445:350W, SFX-8460:450W
- WeightSFX-8445:21kg/46.2lb, SFX-8460:23kg/50.7lb
- Dimensions518(W)x324(H)x324(D)mm
20.4(W)x12.7(H)x12.7(D)in

SFX-8445/8460

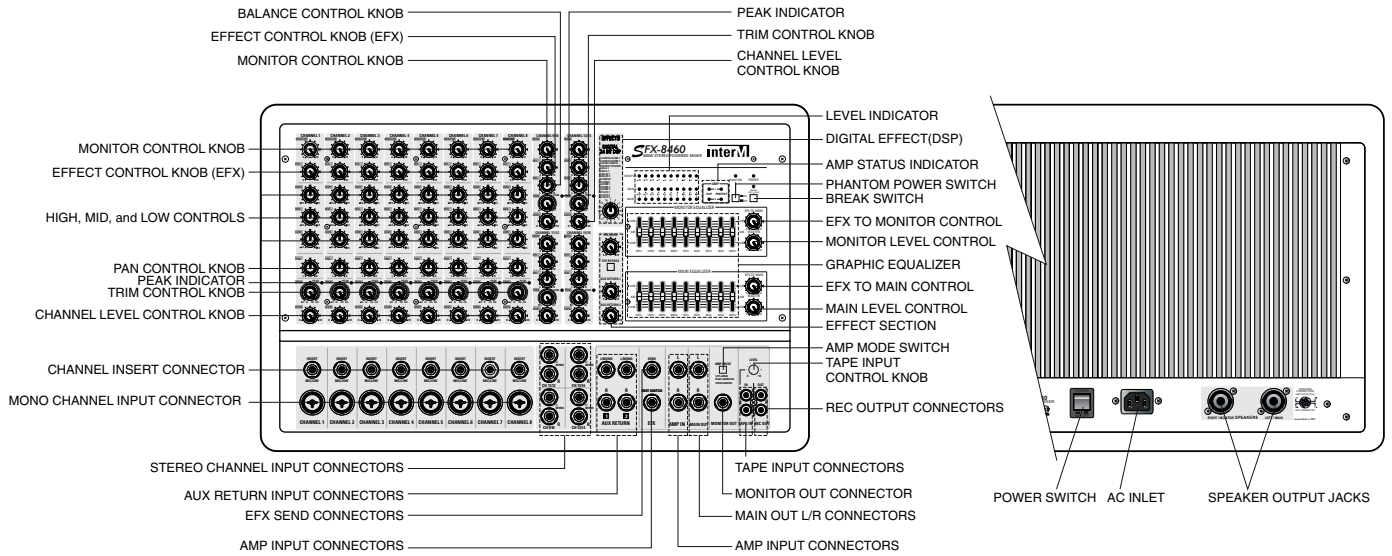

BLOCK DIAGRAM

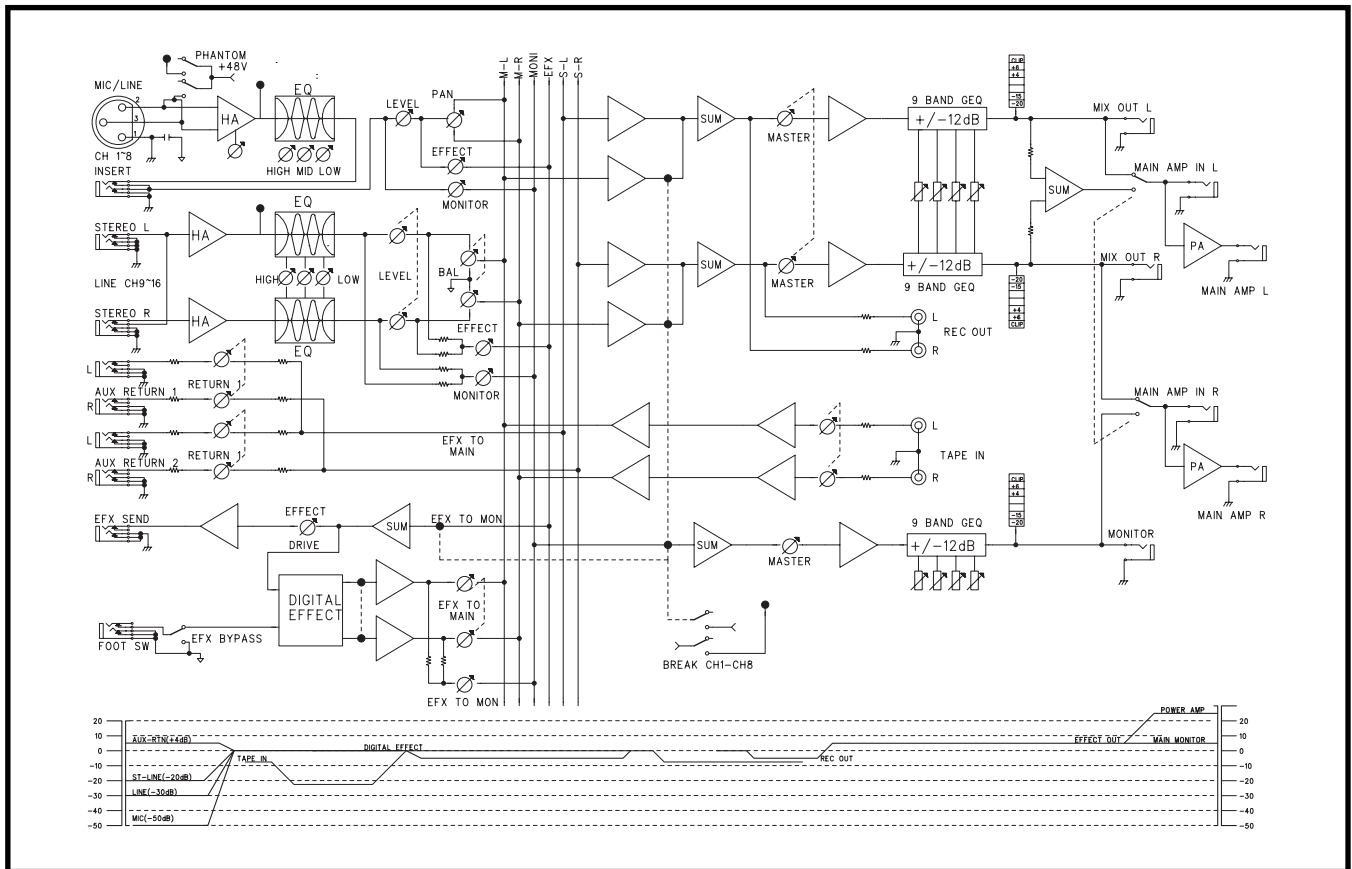

interM

OFFICE : 653-5 BANGHAK-DONG, DOBONG-KU, SEOUL, KOREA TEL : 82-2-2289-8140~8, FAX : 82-2-2289-8149

Home page : <http://www.inter-m.com>

E-mail : export@inter-m.com

9027300110