

# SFX-8250



## SMALL POWERED MIXER



### FEATURES

- 8 Mono inputs 2 and output channels
- 24 BIT digital effects : 1.Chorus-room 1, 2.Chorus-room 2, 3.Voccal cancel, 4.Rotary speaker, 5.Hall 1, 6.Hall 2 7.Delay 1, 8.Delay 2, 9.Chorus, 10.Flange, 11.Room 1, 12.Room 2, 13.Room 3, 14.Plate 1 15.Plate 2, 16.Plate 3
- Amp input jack (Amp in)
- The input signals for the two channels can be selected as monitor+main, main+main,and main(bridged mono).
- Tape in, return  
There are used for play back of tape desk, and other electronic instruments, such as an electronic keyboard.
- Buil-in 7 band graphic equalizer
- +48V Phantom power for each mono channels

### SPECIFICATIONS

- ELECTRICAL \* 0dB=0.775Vrms
  - Rated Output  
Power Amp .....250W+250W, 4  
Main/Monitor .....+4dB/600 , UNBAL
  - Input Sensitivity / Impedance  
Lo-z/Hi-z .....-50dB/40dB, 600 , BAL  
Amp In .....+4dB, UNBAL  
Tape In .....-10dBV/10k , UNBAL  
AUX In .....-10dB/10k , UNBAL
  - Frequency Response(+1 / -2dB) .....20Hz~30kHz
  - THD(20Hz ~ 20kHz)  
Mixer Section .....0.1%  
Amp Section .....0.5%
  - Tone Control(High, Mid, Low)  
High, Low(12kHz, 80Hz).....±15dB  
Mid(2.5kHz) .....±12dB
  - Graphic Equalizer ±12dB) .....  
7 Band (63Hz, 160Hz, 400Hz, 1k,2.5k,6.4k,12k)
  - EIN .....-128dB
  - Buss Noise .....-78dB
  - CrossTalk .....-70dB
- GENERAL
  - Power Source .....100-120VAC or 220-240VAC; 50/60Hz  
(Supplied AC mains transformer depends on country requirements)
  - Power Consumption .....450W
  - Weight ..... 16.5kg/36.3lb
  - Dimensions .....412(W) x 257(H) x 300(D)mm  
19(W) x 3.5(H) x 11(D)in

# SFX-8250

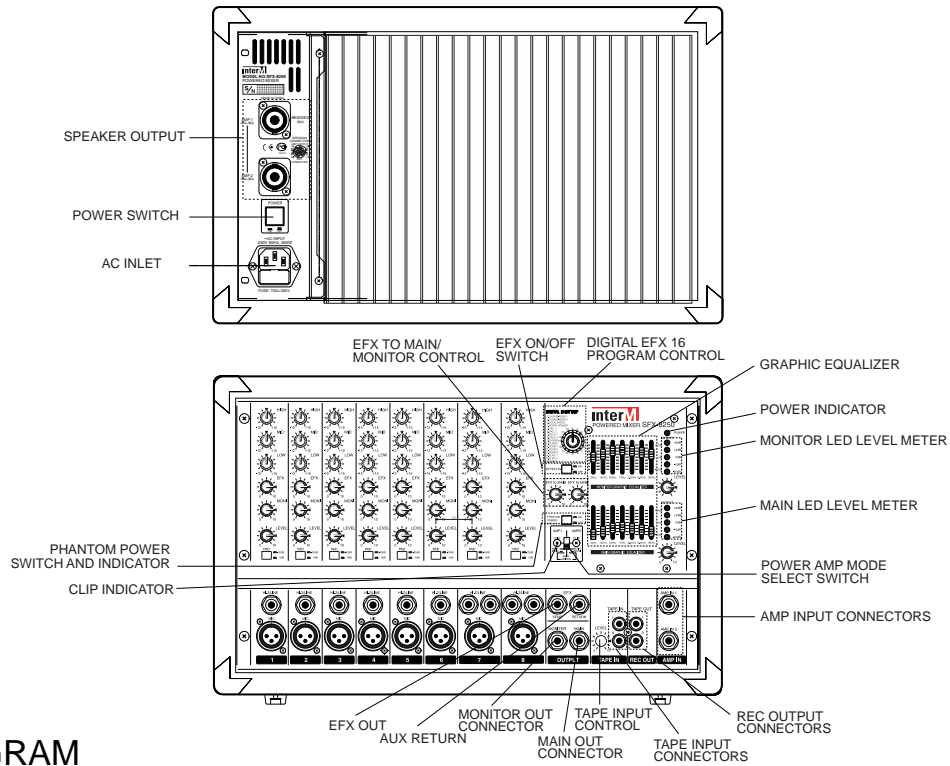

## BLOCK DIAGRAM

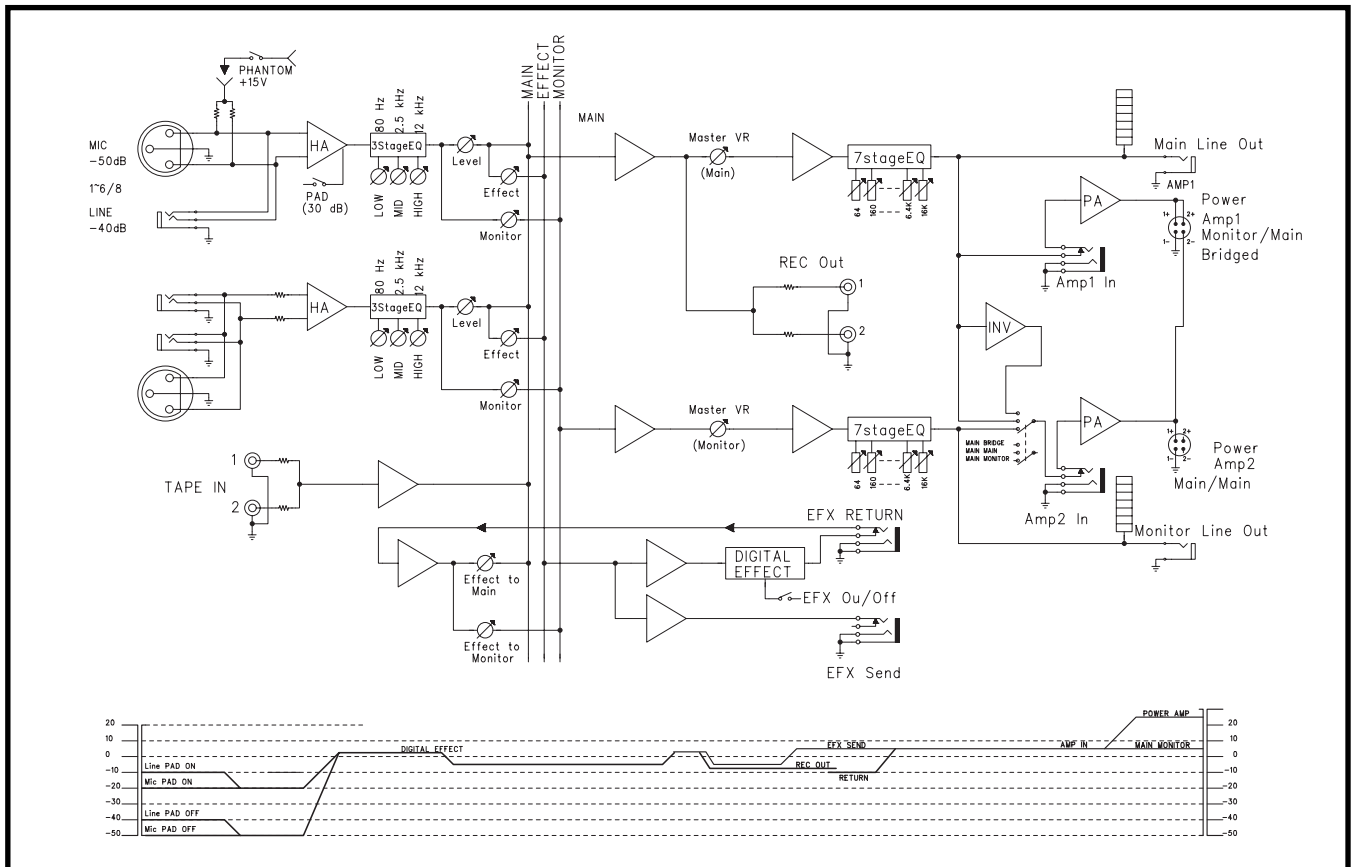

OFFICE : 653-5 BANGHAK-DONG, DOBONG-KU, SEOUL, KOREA TEL : 82-2-2289-8140~8, FAX : 82-2-2289-8149  
 Home page : <http://www.inter-m.com> E-mail : [export@inter-m.com](mailto:export@inter-m.com)