

MX-1436/1436EX/1836/1836EX/2236/2236EX

interM

STEREO MIXING CONSOLE



FEATURES

- 6 MONO(MX-1436, 1436EX), 10 MONO (MX-1836, 1836EX), 14 MONO(MX-2236, 2236EX) INPUT AND 4 STEREO INPUT
Any sound source of microphones, cassette decks, electronic guitars, organs can be applied to the channel input.
- MAIN MIX L/R AND 4-GROUP OUTPUT.
Main mix L/R and 4-Group are provided for convenient use.
- 2 AUX RETURN, 2 AUX SEND AND 1 EFX SEND
For convenient use of external equipment, AUX SEND and AUX RETURN function are provided.
- CHANNEL EQUALIZER
The 3 band equalizer with sweepable mid-range frequency are designed for $\pm 15\text{dB}$ control on mono input channel. The 4 band equalizer are designed for $\pm 15\text{dB}$ control on stereo input channel.
- SOLO FUNCTION OF ALL CHs.
The SOLO function allows you to monitor through headphone any input channel after the channel fader.
- MULTI MODE EFFECT(ONLY 1436EX/1836EX/2236EX)
32-bit SHARC DSP, 8 Bank, 32 Preset effect and Threshold control for LIM/COMP Audiophile-quality 9Band true Digital Graphic Equalizer.
- PHANTOM POWER(+48V)
Phantom power is provided for easy connection of condenser microphones requiring an external power supply.

SPECIFICATIONS

- ELECTRICAL *0dB=0.775Vrms
 - Input Sensitivity/Impedance
 - Mic-60dB/4k Ω (BAL)
 - Line-20dB/10k Ω (BAL)
 - AUX+4dB/10k Ω (UNBAL)
 - Tape Return-10dBV/10k Ω (UNBAL)
 - Rated Output
 - Mix L/R+4dB/150 Ω (BAL)
 - Group 1-4+4dB/75 Ω (UNBAL)
 - CTRL. Room+4dB/75 Ω (UNBAL)
 - AUX Send.....+4dB/75 Ω (UNBAL)
 - Insert0dB/600 Ω
 - Phone.....3mW/100 Ω
 - Frequency Response(+1dB, -2dB)20Hz~20kHz
 - T.H.D(20Hz~20kHz)0.1%
 - EIN-128dB
 - Tone Control
 - High(12kHz)..... $\pm 15\text{dB}$
 - Mid(250~5kHz) $\pm 15\text{dB}$
 - Low(80Hz) $\pm 15\text{dB}$
- GENERAL
 - Power SourceAC 100V-240V, 50/60Hz
 - Power Consumption.....MX-1436(EX):30W
MX-1836(EX):35W
MX-2236(EX):40W
 - WeightMX-1436(EX):7kg
MX-1836(EX):8kg
MX-2236(EX):9kg
 - DimensionsMX-1436(EX):482(W)x90(H)x354(D)mm
MX-1836(EX):556(W)x90(H)x354(D)mm
MX-2236(EX):672(W)x90(H)x354(D)mm

MX-1436/1436EX/1836/1836EX/2236/2236EX

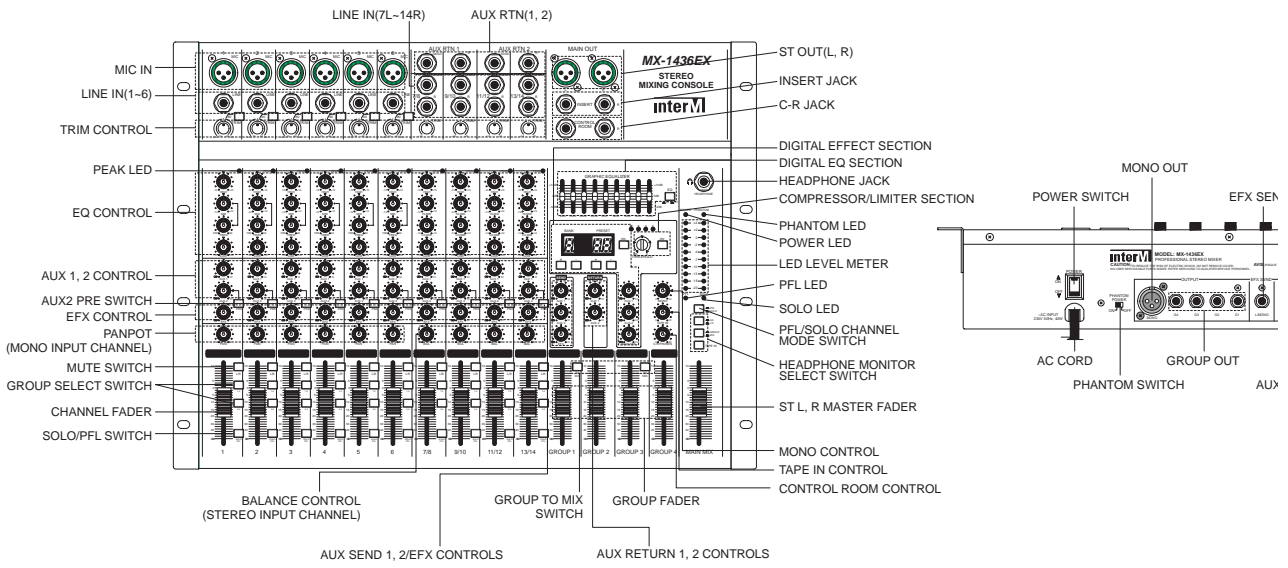

BLOCK DIAGRAM

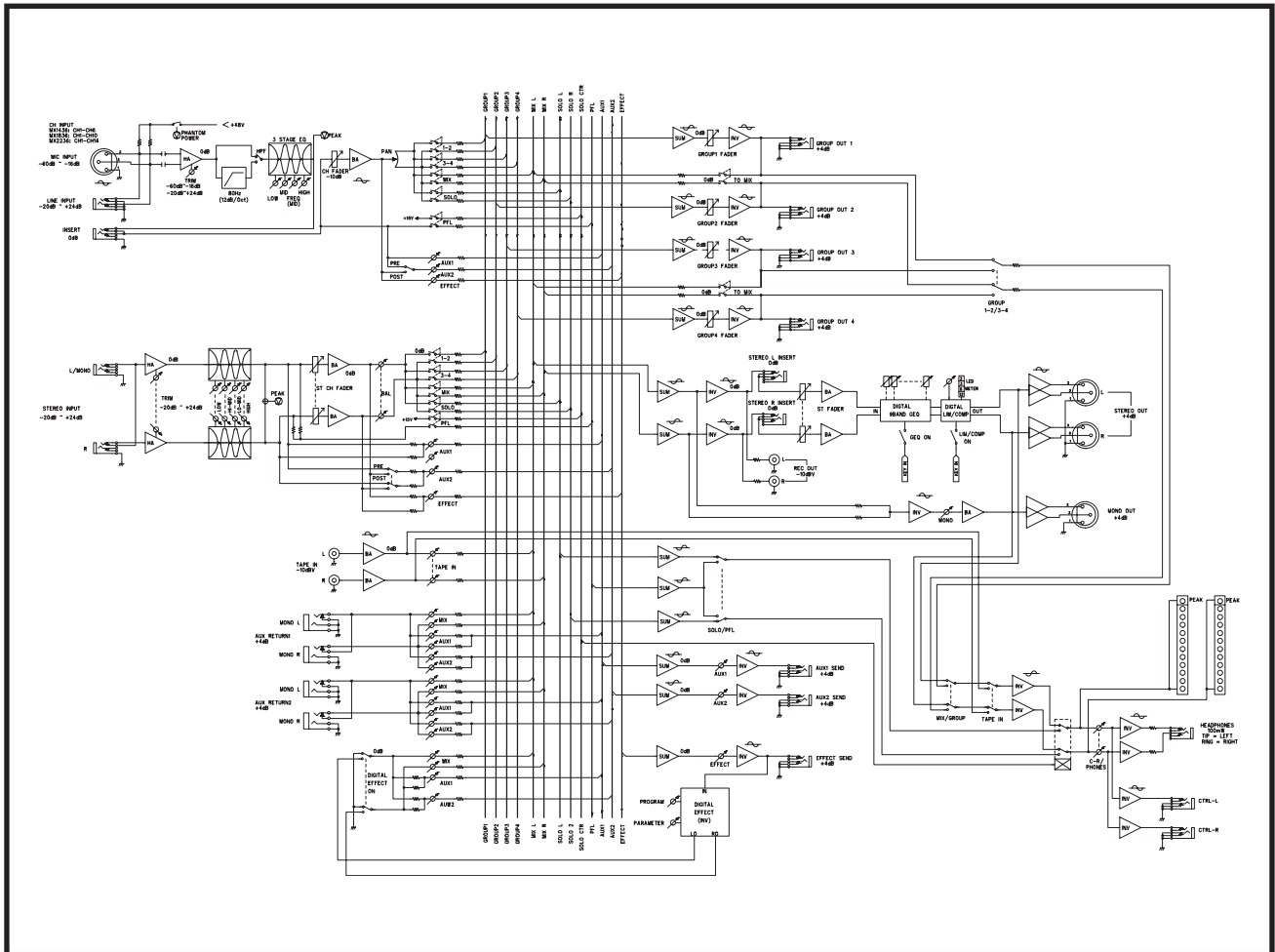

interM

OFFICE : 653-5 BANGHAK-DONG, DOBONG-KU, SEOUL, KOREA TEL : 82-2-2289-8140~8, FAX : 82-2-2289-8149

Home page : <http://www.inter-m.com>

E-mail : export@inter-m.com

9047932910