

PROFESSIONAL AUDIO MIXER



FEATURES

- **12 CH INPUT AND 4 OUTPUT**
Any sound source of microphones, cassette decks, electronic guitars, organs can be applied to the 12 channel input, and 4 AUX SEND, MONO OUT and MAIN L,R OUT are provided for convenient use.
- **3 BAND TONE CONTROLS**
3 band tone controls are provided to adjust the acoustic characteristics according to microphones, speakers and room structured.
- **AUX SEND AND AUX RETURN**
For the convenient use of effect equipment, reverb, delay or phasor AUX SEND and AUX RETURN function are provided.
- **OUTPUT MONITORING**
You can monitor by LED meter and headphone.
- **PFL FUNCTION**
The PFL/AFL function allows you to monitor through headphone any input channel before the channel fader and AUX output channel after the AUX SEND volume.
- **+48V PHANTOM POWER**
Phantom power is provided for easy connection of condenser microphones requiring an external power supply.

SPECIFICATIONS

- **ELECTRICAL** *0dB=0.775Vrms
 - Rated Output/Impedance
 - Stereo L/R.....+4dB/600Ω, BAL
 - Mono.....+4dB/600Ω, BAL
 - AUX Send 1~4.....+4dB/600Ω, UNBAL
 - Headphone.....100mW/40Ω
 - Input Sensitivity/Impedance
 - Mic(CH1~12)-60dB/600Ω, BAL
 - Line(CH1~12)-20dB/10kΩ, BAL
 - AUX Return+24dB/10kΩ, UNBAL
 - T.H.D(20Hz~20kHz).....0.1%
 - Frequency Response(+1/-2dB).....20Hz~20kHz
 - Tone Control
 - High(shelving)±12dB(Max ±15dB)
 - Mid(peaking)±12dB
 - Low(shelving)±12dB(Max ±15dB)
 - EIN.....-127dB
 - Residual Noise.....-95dB
 - Crosstalk.....-70dB
- **GENERAL**
 - Power Source.....AC 110V~240V, 50/60Hz
 - Power Consumption.....25W
 - Weight.....7.5kg
 - Dimensions.....482(W) × 104(H) × 310(D)mm

MX-1243

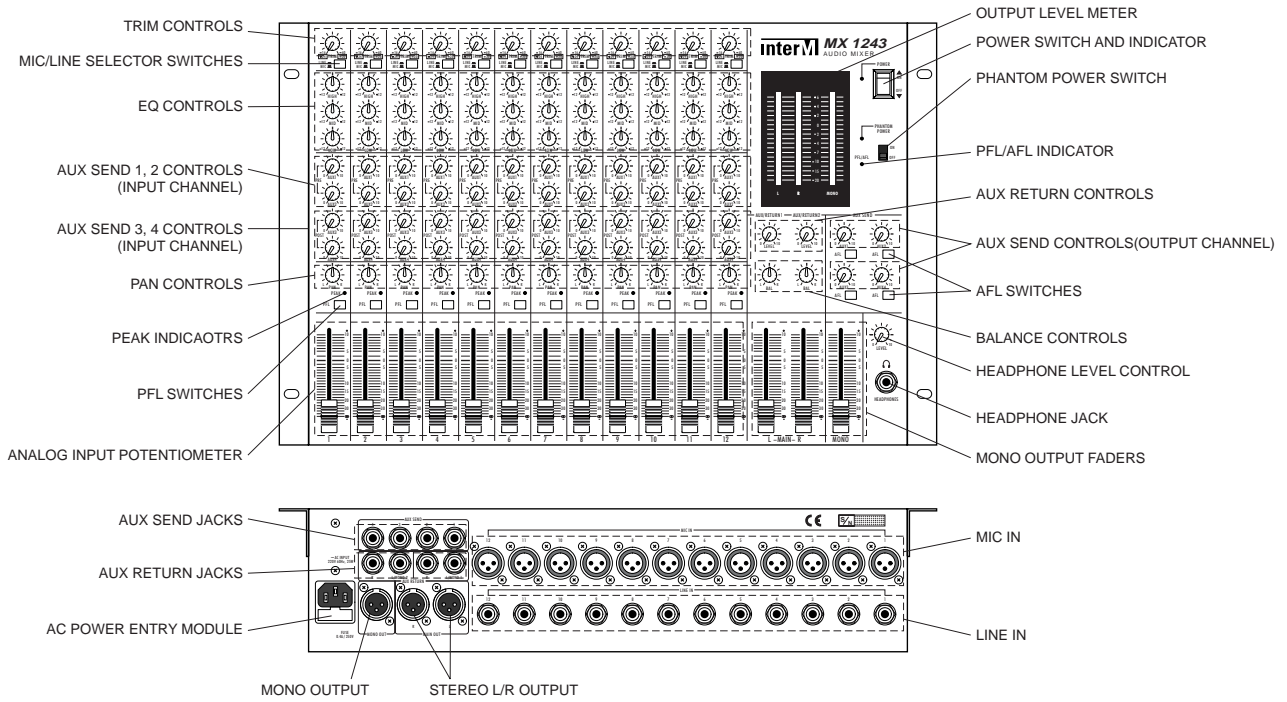

BLOCK DIAGRAM

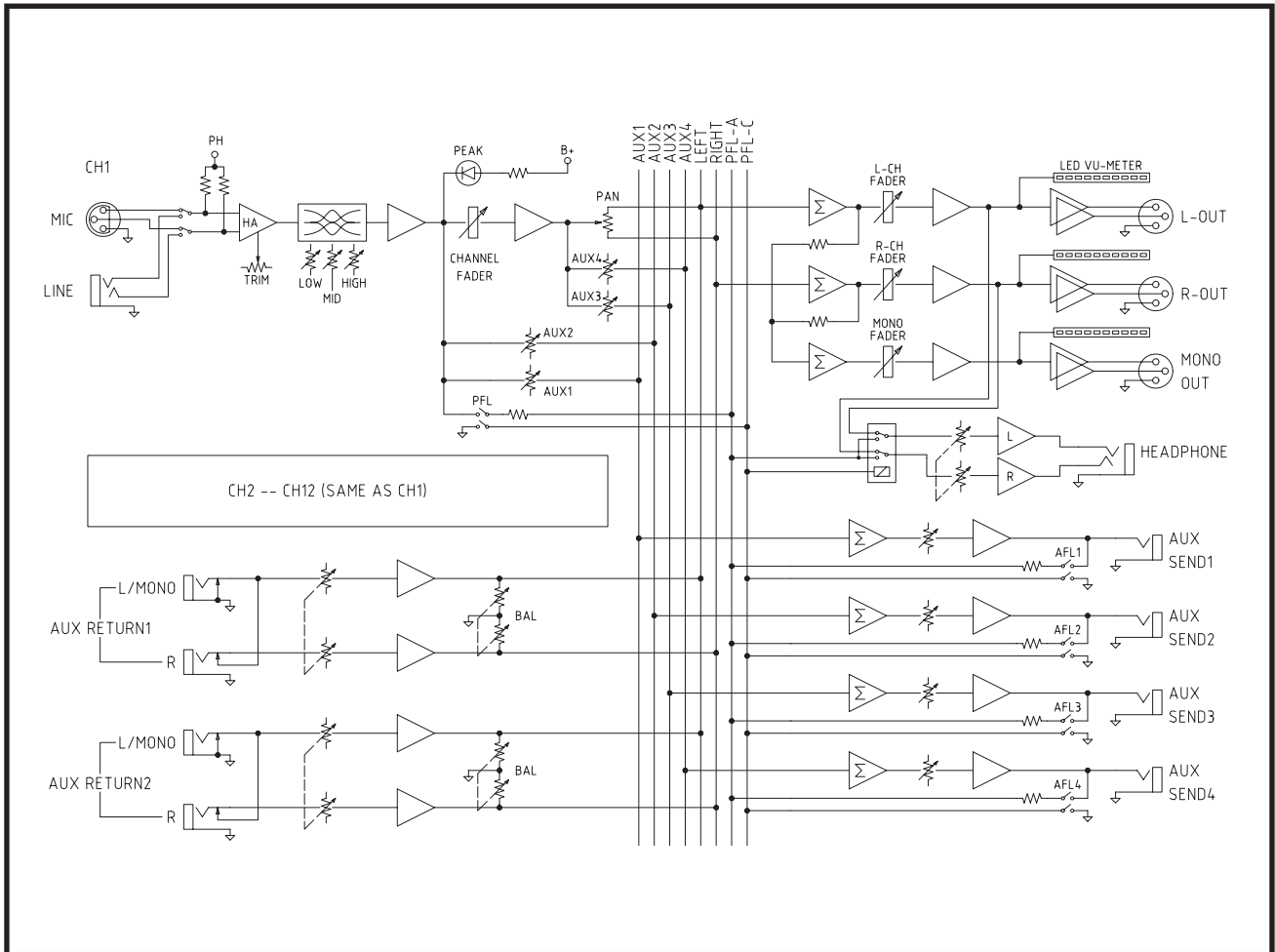

interM

OFFICE : 653-5 BANGHAK-DONG, DOBONG-KU, SEOUL, KOREA TEL : 82-2-2289-8140~8, FAX : 82-2-2289-8149

Home page : <http://www.inter-m.com>

E-mail : export@inter-m.com

9047924410 A