

ATTENUATOR UNIT



ATT-01

ATT-03

ATT-30

FEATURES

- ATTENUATOR UNIT FOR MODULE PLATE
- ELEGANT DESIGN
Smart and modern design to match the interior.
- SIMPLE INSTALLATION
Simple installation by module plate.
- EASY WIRING
Screw less terminal block makes wiring very easy.

SPECIFICATIONS

■ ELECTRICAL

	ATT-01	ATT-03	ATT-30
Rated Input	1W	3W	30W
Application Watt	1W	2~3W	7~30W
Input Impedance (Reference Voltage 100V)	10kΩ	5kΩ~3.3kΩ	1.4kΩ~330Ω
Volume Control	4 STEP SW (-∞, -10, -4, 0dB)	4 STEP SW (-∞, -10, -4, 0dB)	4 STEP SW (-∞, -12, -6, 0dB)
Method	RESISTOR	RESISTOR	TRANSFORMER
Material			
Plate	SECC 1.0T		
Front Cover	A.B.S		

■ GENERAL

- WeightATT-01:109g
ATT-03:112g
ATT-30:196g
- Dimensions.....68(W) × 120(H) × 38(D)mm

WIRING METHOD

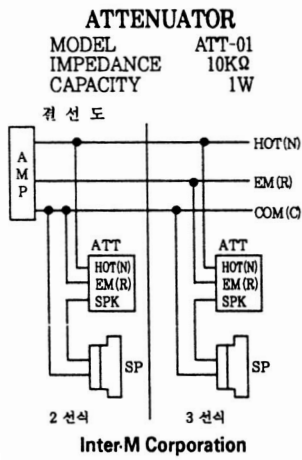

ATT-01

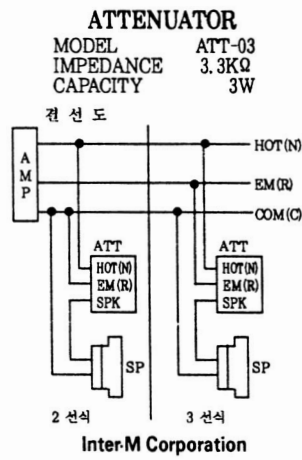

ATT-03

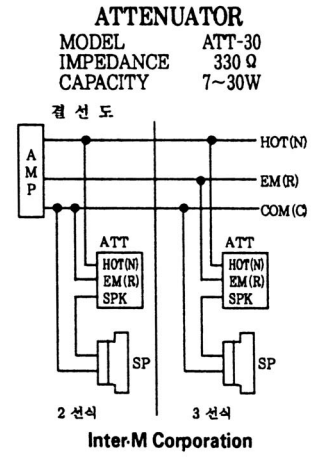

ATT-30

SCHEMATIC DIAGRAM

