

VD-560V (NTSC) / VD-561V (PAL)



3-Axis Vandal Proof Dome Camera



Features

- 1/3" SONY Super HAD CCD Sensor
- 560 TV Lines
- Built-in Varifocal Lens (f=4 ~ 9mm)
- OSD (On Screen Display), DSS (Digital Slow Shutter)
- SDNR (Super Digital Noise Reduction)
- Auto White Balance
- AGC, BLC, Flickerless (On/Off)
- Min. Illumination 0.0008 Lux
- 3-Axis Bracket
- Ivory / Black Housing

Dimensions (UNIT : mm)

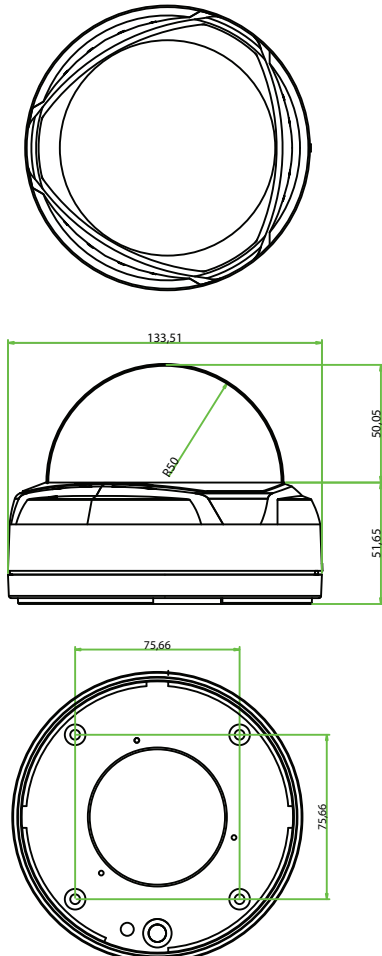

Specification

ITEM	VD-560V	VD-561V
Signal System	NTSC	PAL
Image Sensor	1/3" SONY Super HAD CCD	
Total/Effective Pixels	410K/380K	470K/440K
Resolution	560 TV lines	
Shutter Speed	1/60~1/120,000 sec.	1/50~1/120,000 sec.
Video Output	VBS 1.0Vp-p(75 Ω Composite)	
Sync. System	Internal	
Scanning System	2:1 Interlace	
S/N Ratio	More than 50dB	
Min. Illumination	0.1 Lux / 0.0008 Lux	
Lens	DC Iris Varifocal lens (4~9mm)	
AGC	Off / Low / Middle / High	
Mirror Function	On / Off (Horizontal)	
Sharpness Control	On / Off (Level Adjustable)	
Privacy Zone	On / Off	
White Balance	ATW (1800K ~ 10,500K) / AWC / Manual	
Power Supply	DC 12V (10V ~ 15V)	
Operating Temp.	-10°C ~ +55°C	
Dimension	133.51 mm(W) x 101.7mm(H)	

Specification are subject to change without any prior notice.