

# VD-530 (NTSC) / VD-531 (PAL)



## 3-Axis Vandal Proof Dome Camera



### Features

- 1/3" SONY Super HAD CCD Sensor
- 530 TV Lines
- Built-in fixed Lens (f=3.6mm)  
4mm, 6mm (optional)
- Min. Illumination 0.3 Lux
- 3-Axis Bracket
- Ivory / Black Housing

### Specification

ITEM	VD-530	VD-531
Signal System	NTSC	PAL
Image Sensor	1/3" SONY Super HAD CCD	
Scanning Frequency(H)	15.734 KHz	15.625 KHz
Scanning Frequency(V)	59.94 Hz	50 Hz
Total Pixels Number	811(H) x 508(V) 410K	795(H) x 596(V) 470K
Effective Pixels Number	768(H) x 494(V) 380K	752(H) x 582(V) 440K
Resolution	530 TV lines	
Shutter Speed	1/60~1/100,000 sec.	1/50~1/100,000 sec.
Video Output	VBS 1.0Vp-p(75Ω Composite)	
Sync. System	Internal	
Scanning System	2:1 Interlace	
S/N Ratio	More than 50dB (AGC Off)	
Min. Illumination	0.3 Lux	
Lens	Fixed lens (3.6mm) 4mm, 6mm (optional)	
Focus Mode	Manual	
White Balance	Auto	
Housing material	Aluminium (Vandal-Resistant)	
Lens Rotation	3-Axis mechanism	
Mount Type	Surface	
Supplied Voltage	DC12V or DC12V/AC24V Dual Voltage optional	
Dimension	100(ø) x 102mm(H)	
Weight	Approx. 950g	

### Dimensions (UNIT : mm)

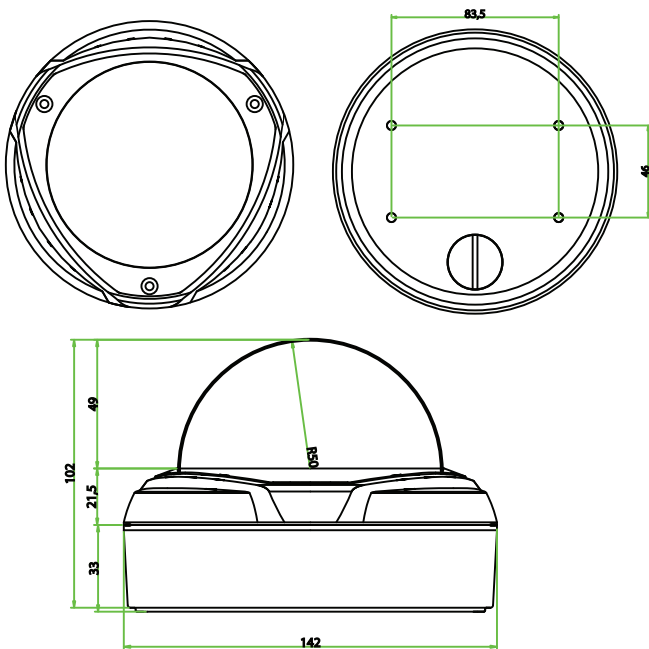

### Wall Mount Bracket (Option)



Specification are subject to change without any prior notice.