

3-Axis Vandal Proof Dome Camera



Features

- 1/3" SONY Super HAD CCD Sensor
- 550 TV Lines
- Dip Switch Controls
- 3-Axis Bracket
- Surface or Flush Mountable
- Ivory Housing

Specification

ITEM	VD-500
Signal System	NTSC
Image Sensor	1/3" SONY Super HAD CCD Sensor
Effective Pixel	768H x 494V
Resolution	550 TV Lines
Shutter Speed	1/60~1/10,000 sec.
Video Output	VBS 1.0Vp-p(75Ω Load)
Sync. System	Internal
Scanning System	2:1 Interlaced
S/N Ratio	Over 48dB
Min. Illumination	0.3 Lux
Lens Options	Fixed: 3.8 mm
Dip Switch Control	① AGC on / AGC off ② FLC on / FLC off ③ BLC on / BLC off
Gamma	0.45
Power Supply	DC 12V
Operating Temp.	-10℃ ~ +50℃
Dimension	100mm cover x 124.50mm(H)

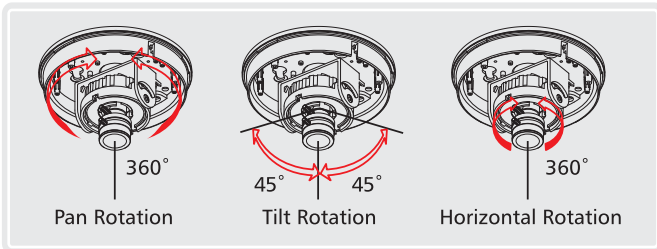

Dimensions (UNIT : mm)

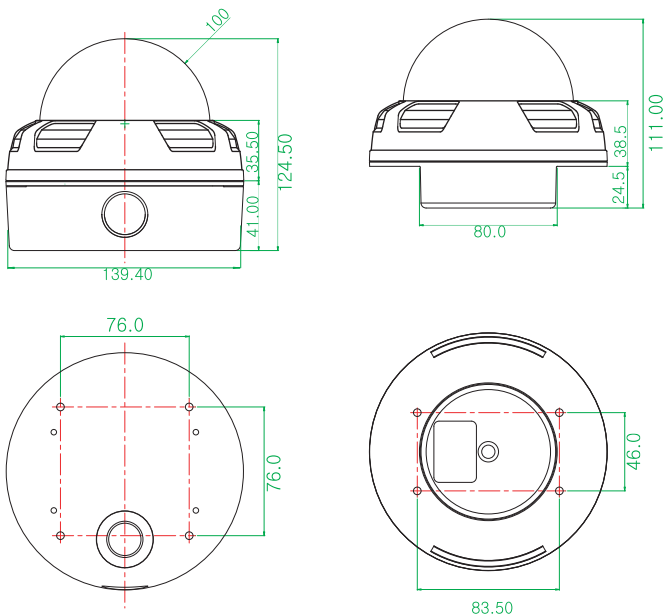

Specification are subject to change without any prior notice.